

1. Prepare the base with suitable height and flat surface
2. Use appropriate fixing anchors to fasten the bracket fixing-backrest assembly

2

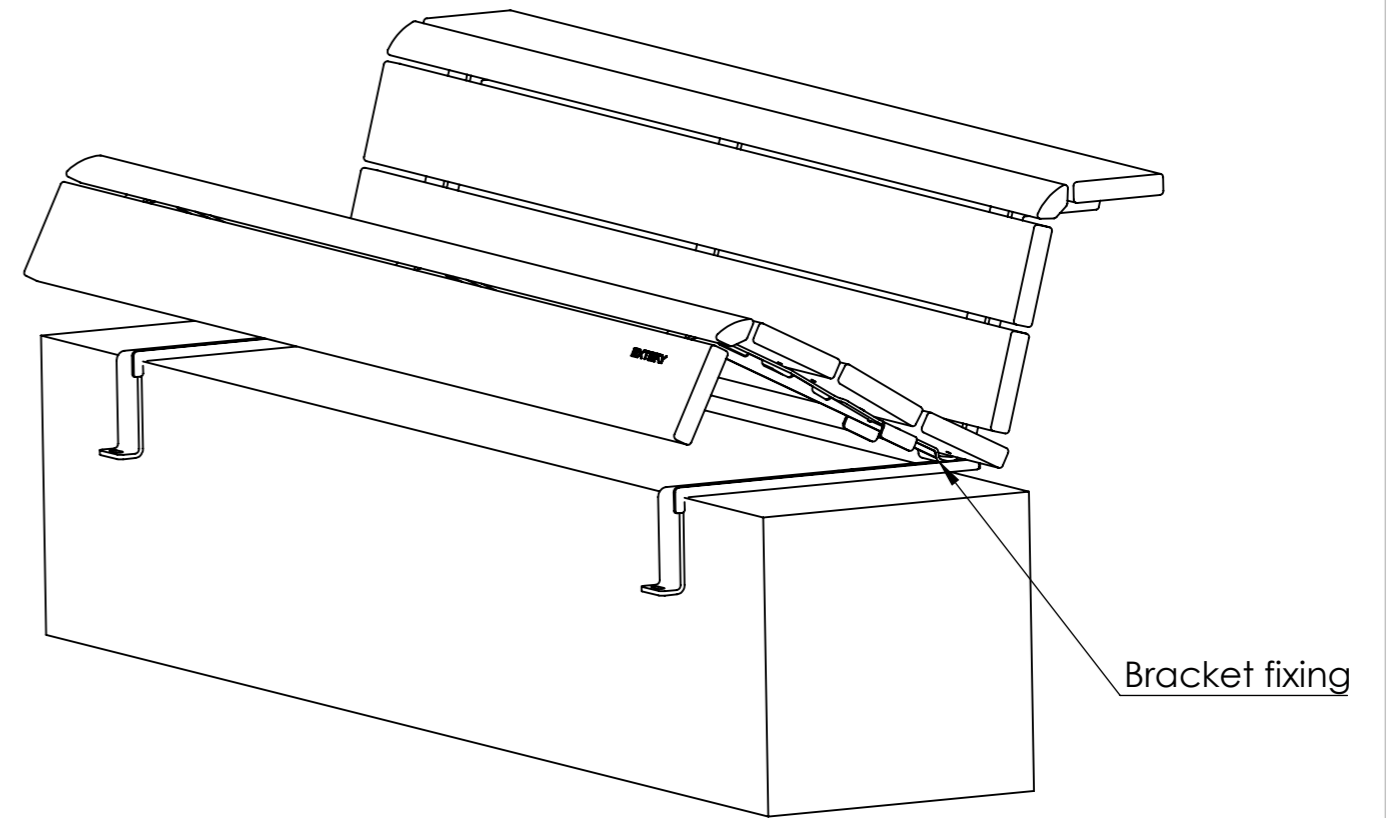

Assemble seat by sliding into bracket fixing at an angle

3

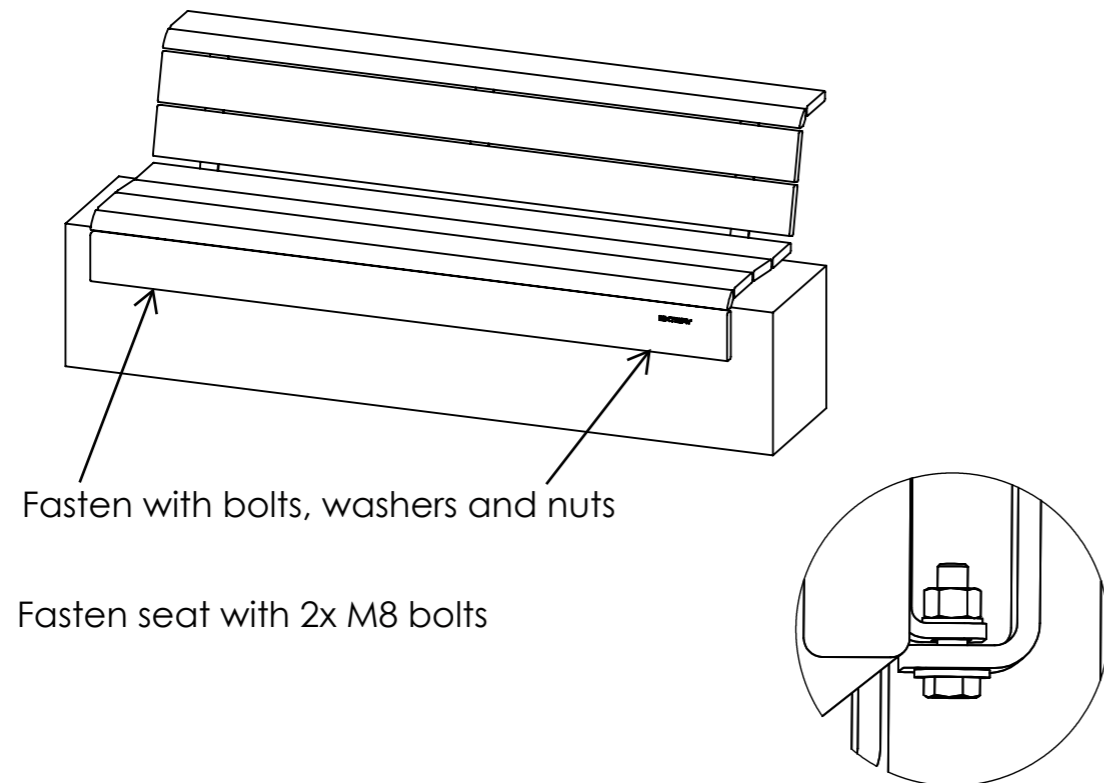

**EXTERY**

Product:

Veer seat with backrest installation\_VERB180

Specification requirements:  
ISO 2768-1

Author:  
H. Lurje

Date:  
21.07.2023

Drawing:  
nr. 1